



Type N Female for CNT-400 braided cable

## Product Classification

<b>Product Type</b>	Braided cable connector
<b>Product Brand</b>	CNT®   ConQuest®

## General Specifications

<b>Body Style</b>	Straight
<b>Inner Contact Attachment Method</b>	Captivated
<b>Inner Contact Plating</b>	Silver
<b>Interface</b>	N Female
<b>Outer Contact Attachment Method</b>	Crimp
<b>Outer Contact Plating</b>	Trimetal

## Dimensions

<b>Width</b>	15.87 mm   0.625 in
<b>Length</b>	40 mm   1.575 in
<b>Diameter</b>	16 mm   0.63 in
<b>Nominal Size</b>	0.405 in

## Outline Drawing

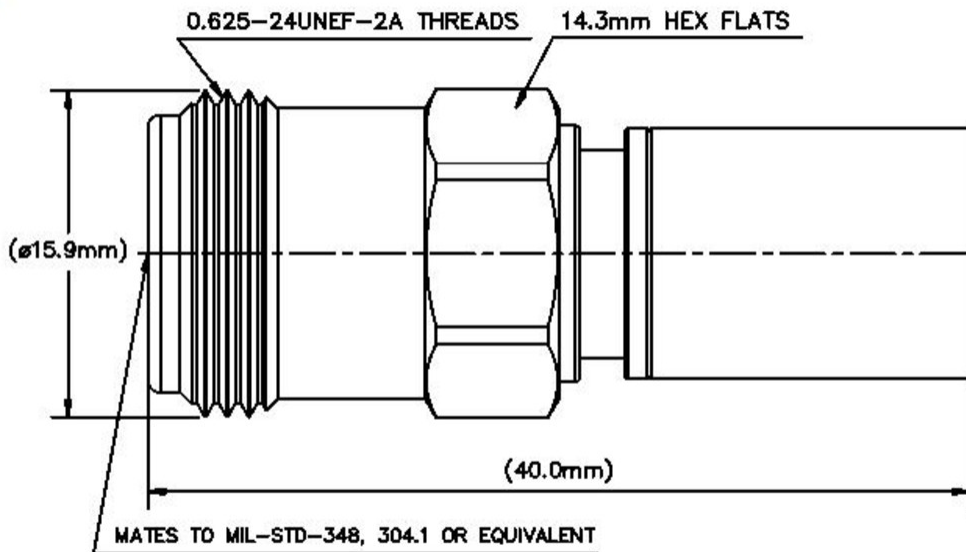

## Electrical Specifications

<b>Insertion Loss, typical</b>	0.05 dB
<b>Cable Impedance</b>	50 ohm
<b>Connector Impedance</b>	50 ohm
<b>dc Test Voltage</b>	2500 V
<b>Inner Contact Resistance, maximum</b>	1 mOhm
<b>Insulation Resistance, minimum</b>	5000 MOhm
<b>Operating Frequency Band</b>	0 – 6000 MHz
<b>Outer Contact Resistance, maximum</b>	0.25 mOhm
<b>Peak Power, maximum</b>	10 kW
<b>RF Operating Voltage, maximum (vrms)</b>	707 V

## VSWR/Return Loss

<b>Frequency Band</b>	<b>VSWR</b>	<b>Return Loss (dB)</b>
<b>0-3000 MHz</b>	1.065	30.05
<b>3000-6000 MHz</b>	1.093	27.05

## Mechanical Specifications

<b>Connector Retention Tensile Force</b>	330 N   74.187 lbf
<b>Connector Retention Torque</b>	0.56 N-m   4.956 in lb
<b>Interface Durability</b>	500 cycles
<b>Interface Durability Method</b>	IEC 61169-16:9.5
<b>Mechanical Shock Test Method</b>	IEC 60068-2-27

## Environmental Specifications

<b>Operating Temperature</b>	-40 °C to +85 °C (-40 °F to +185 °F)
<b>Storage Temperature</b>	-65 °C to +125 °C (-85 °F to +257 °F)
<b>Attenuation, Ambient Temperature</b>	20 °C   68 °F
<b>Average Power, Ambient Temperature</b>	40 °C   104 °F
<b>Average Power, Inner Conductor Temperature</b>	100 °C   212 °F
<b>Climatic Sequence Test Method</b>	IEC 60068-1
<b>Corrosion Test Method</b>	IEC 60068-2-11
<b>Damp Heat Steady State Test Method</b>	IEC 60068-2-3
<b>Thermal Shock Test Method</b>	IEC 60068-2-14
<b>Vibration Test Method</b>	IEC 60068-2-6
<b>Water Jetting Test Mating</b>	Mated
<b>Water Jetting Test Method</b>	IEC 60529:2001, IP65

## Packaging and Weights

<b>Weight, net</b>	26.56 g   0.059 lb
--------------------	--------------------

## Regulatory Compliance/Certifications

<b>Agency</b>	<b>Classification</b>
CHINA-ROHS	Above maximum concentration value
ISO 9001:2015	Designed, manufactured and/or distributed under this quality management system
ROHS	Compliant/Exempted



## \* Footnotes

# 400BPNF-C-CR 苏州启道 - 康普安德鲁 HELIAX 中国区独家授权总代理

---

**Insertion Loss, typical** 0.05V<sup>-1</sup>freq (GHz) (not applicable for elliptical waveguide)