



7-16 DIN Female for 3/8 in FSJ2 and PTS2 cable

## Product Classification

<b>Product Type</b>	Wireless and radiating connector
<b>Product Brand</b>	HELIAX®

## General Specifications

<b>Body Style</b>	Straight
<b>Cable Family</b>	FSJ2-50
<b>Inner Contact Attachment Method</b>	Captivated
<b>Inner Contact Plating</b>	Silver
<b>Interface</b>	7-16 DIN Female
<b>Mounting Angle</b>	Straight
<b>Outer Contact Attachment Method</b>	Compression
<b>Outer Contact Plating</b>	Silver
<b>Pressurizable</b>	No

## Dimensions

<b>Height</b>	28.96 mm   1.14 in
<b>Width</b>	28.96 mm   1.14 in
<b>Length</b>	51.56 mm   2.03 in
<b>Diameter</b>	28.96 mm   1.14 in
<b>Nominal Size</b>	3/8 in

## Outline Drawing

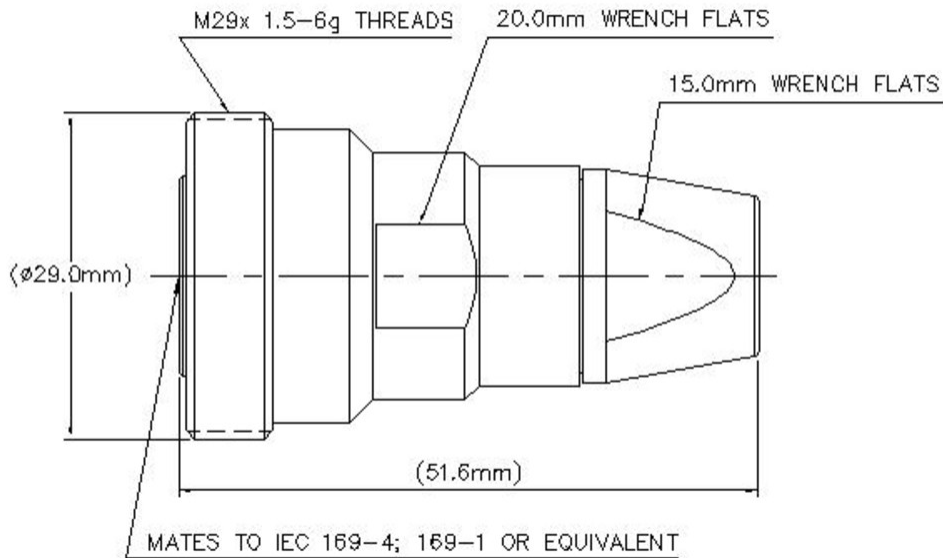

## Electrical Specifications

<b>3rd Order IMD at Frequency</b>	-112 dBm @ 910 MHz
<b>3rd Order IMD Test Method</b>	Two +43 dBm carriers
<b>Average Power at Frequency</b>	0.7 kW @ 900 MHz
<b>Cable Impedance</b>	50 ohm
<b>Connector Impedance</b>	50 ohm
<b>dc Test Voltage</b>	2300 V
<b>Inner Contact Resistance, maximum</b>	0.4 mOhm
<b>Insulation Resistance, minimum</b>	10000 MOhm
<b>Operating Frequency Band</b>	0 – 6000 MHz
<b>Outer Contact Resistance, maximum</b>	1.5 mOhm
<b>Peak Power, maximum</b>	13.2 kW
<b>RF Operating Voltage, maximum (vrms)</b>	813 V
<b>Shielding Effectiveness</b>	-110 dB

## VSWR/Return Loss

Frequency Band	VSWR	Return Loss (dB)
0-2000 MHz	1.07	30

## Mechanical Specifications

<b>Connector Retention Tensile Force</b>	671.68 N   151 lbf
<b>Connector Retention Torque</b>	2.7 N-m   23.897 in lb
<b>Coupling Nut Proof Torque</b>	35 N-m   309.776 in lb
<b>Coupling Nut Proof Torque Method</b>	IEC 61169-16:9.3.11
<b>Coupling Nut Retention Force</b>	1000 N   224.81 lbf
<b>Coupling Nut Retention Force Method</b>	IEC 61169-17:9.3.11
<b>Insertion Force</b>	889.64 N   200 lbf
<b>Insertion Force Method</b>	IEC 61169-16:9.3.5
<b>Interface Durability</b>	500 cycles
<b>Interface Durability Method</b>	IEC 61169-4:17
<b>Mechanical Shock Test Method</b>	IEC 60068-2-27

## Environmental Specifications

<b>Operating Temperature</b>	-55 °C to +85 °C (-67 °F to +185 °F)
<b>Storage Temperature</b>	-65 °C to +125 °C (-85 °F to +257 °F)
<b>Attenuation, Ambient Temperature</b>	20 °C   68 °F
<b>Average Power, Ambient Temperature</b>	40 °C   104 °F
<b>Average Power, Inner Conductor Temperature</b>	100 °C   212 °F
<b>Corrosion Test Method</b>	IEC 60068-2-11
<b>Immersion Depth</b>	1 m
<b>Immersion Test Mating</b>	Mated
<b>Immersion Test Method</b>	IEC 60529:2001, IP68
<b>Moisture Resistance Test Method</b>	IEC 60068-2-3
<b>Thermal Shock Test Method</b>	IEC 60068-2-14
<b>Vibration Test Method</b>	IEC 60068-2-6

## Packaging and Weights

<b>Weight, net</b>	107.47 g   0.237 lb
--------------------	---------------------

## Regulatory Compliance/Certifications

<b>Agency</b>	<b>Classification</b>
CHINA-ROHS	Below maximum concentration value
ISO 9001:2015	Designed, manufactured and/or distributed under this quality management system

REACH-SVHC

Compliant as per SVHC revision on [www.commscope.com/ProductCompliance](http://www.commscope.com/ProductCompliance)

ROHS

Compliant



### \* Footnotes

#### **Immersion Depth**

Immersion at specified depth for 24 hours